



TWENTY
TWO  PRO

TwentyTwo Pro Installation Guide



I N T R O D U C T I O N

This manual and the functions described in it, are valid for the installation of VCHRGD Technologies tethered and socketed, 22kW AC Pro Series chargers. It's designed for use exclusively by trained, qualified personnel to aid them in the installation and commissioning of the VCHRGD TwentyTwo Pro.

These are people who, due to their training, skills, experience and knowledge of the relevant standards, can assess the work assigned to them and identify possible dangers and any protective devices required to meet the region's relevant wiring standards and regulations.

The illustrations and explanations contained in this manual refer to a typical version of the device. Your device version should not, but may differ from this.

Please refer to the manual for information and instructions on operating the device, fault identification and commissioning.



INTRODUCTION

PRODUCT FEATURES



KEY FEATURES

Load Balancing

Hard-wired dynamic load balancing with CT's provided in box. Never overload your main supply

Robust Casing

Robust IK10 rated ABS casing. Chargers built to last in any environment

Push Fit

Simple installation with modular charging hardware, increased wiring area & push fit connection

PEN Protection

Simplified installation and reduced project costs, through built in PEN protection

RFID

Built-in RFID reader for easy charge card registration and local charge authorisation

OCPP 1.6

OCPP 1.6 compliant for easy integration with a plethora of back-end service providers

Universal Socket

Universal Type 2 socket for flexibility and future proof commercial charging

Secure

Compliant with all UK smart charging standards & encrypted bluetooth, WiFi & RFID

Cable Lock

Turning untethered chargers into tethered at the touch of a button. Secure your cable

Connected

Configurable connectivity with WiFi, 4G and Ethernet. Your connection, your choice

S P E C I F I C A T I O N

KEY SPECIFICATIONS

Electrical Characteristics

Charger Type	Mode 3 (IEC61851-1)
Nominal Supply	Single phase 230V / Three Phase 400V, 50Hz
Charging Power	Up to 32A (22kW)
Over Current Protection	40A
Current rating	Adjustable (6A to 32A)
Standby Power Consumption	<2.5W
Earth Leakage Protection	AC 30mA + DC 6mA
PEN Protection	BS7671:722.411.4.1 Ident V
Supply Connection	L1,L2, L3, N + PE / CT1 + CT2 + CT3 + PV+/-

Connectivity

WiFi	(IEEE 802.11bgn) @ 2.4Ghz WPA-2
Connection security	Transport Layer Secure Encryption HTTPS
Bluetooth	2.4GHz
RFID	~ 120 -140kHz
4G Cellular	~ 600 MHz -2.5 GHz

Mechanical Features

Connector	Type 2 IEC62196
Mounting	Wall or Pedestal
Dimension (mm)	300 (L) 180 (H) 90 (D)
Weight	3.5kg approx
IP Class/IK Class	IP54 / IK10

Safety & Operational Ratings

Status	LED Indication, Mobile Application (OCPP 1.6j)
Operating Ambient Temperature	-25°C to 50°C
Relative Humidity	5% -95%
Atmospheric Pressure	80kPA -110kPA
EMC Compliance	IEC61000-4
Integral Protection	Under & Over Voltage, Temperature & Current 6mA DC Leakage, RCDD PEN Fault Detection

P A C K A G I N G

I N S I D E T H E B O X

I N T E R N A L P A C K A G I N G

I N T E R N A L P R O T E C T I V E P A C K A G I N G

KEEP ME GUIDE, FIXINGS PACK, 2X RFID CARDS



C H A R G E P O I N T

7KW CHARGEPOINT W/ CABLE IF TETHERED

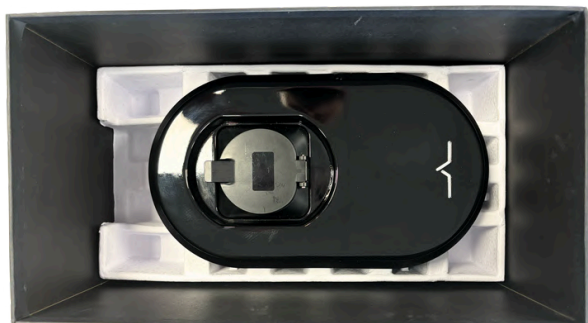

E X T E R N A L P A C K A G I N G

P R O T E C T I V E C A R D B O A R D M A T T E F I N I S H A N T I - S C U F F S L E E V E , R I G I D C A R D B O A R D C O R E

P A C K A G I N G W I T H I N T E R N A L P R O T E C T I O N



100% RECYCLABLE

A L L P A C K A G I N G M A T E R I A L S A R E 100% R E C Y C L A B L E A N D S H O U L D B E R E S P O N S I B L Y D I S P O S E D O F A F T E R I N S T A L L A T I O N



• F I X T U R E S

4 X WALL MOUNTING SCREWS
 4 X WALL PLUGS
 3 X FERRULES
 1 X TORX+ DRILL BIT
 5 X TORX+ BACK BOX SCREWS



• C T C L A M P

3 X CT CLAMPS AS STANDARD

EASTON SPLIT CORE CT 120A
 RATED INPUT 40MA OUTPUT
 0.5% ACCURACY

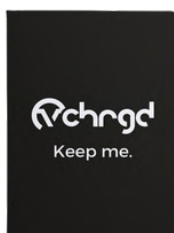

• K E E P M E G U I D E

COMMISSIONING & SET UP GUIDE
 TO BE LEFT WITH CUSTOMER
 INSTALLER PASSWORD, APP SET
 UP CREDENTIALS & QR CODES TO
 DOWNLOAD USER/INSTALL APPS



• R F I D C A R D S

2 X TAP & CHARGE RFID CARDS
 USED TO AUTHORISE CHARGING
 IN TANDEM WITH VCHRGD HOME
 APP, OR IN STANDALONE RFID
 MODE IF NO DATA CONNECTION

N O T E | I T I S I M P O R T A N T T O E N S U R E T H A T T H E C U S T O M E R R E T A I N S T H E K E E P M E G U I D E F O R H O M E A P P S I G N U P A N D O N G O I N G S U P P O R T P U R P O S E S .

I N S T A L L A T I O N

G E T T I N G S T A R T E D

This electrical device should only be installed, operated, serviced and maintained by qualified personnel. No responsibility is assumed by the manufacturer for any consequences arising from the use of this device. A qualified person is one who has skills and knowledge related to the construction, installation and operation of electrical devices and who has received safety training to recognise and avoid the hazards involved.

All applicable local, regional, and national regulations must be respected when installing, repairing, and maintaining this device. In the UK the predominant wiring standards are BS7671 and it may be necessary to alert the Distribution Network Operator (DNO) prior to carrying out your installation.

T O O L S R E Q U I R E D

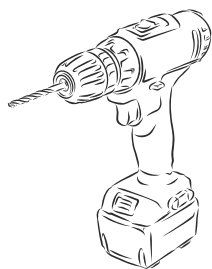

D R I L L

SDS OR APPROPRIATE
POWER DRILL WITH 6MM
DRILL BIT SUITED TO
MOUNTING SURFACE

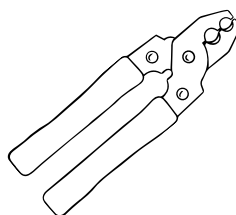

C R I M P / C U T

SUITABLE CRIMPING TOOLS TO
SECURE FERRULES IN PLACE TO
TERMINAL CORES AND WIRE
CUTTERS SUITED TO CHOSEN
CABLE DIAMETER

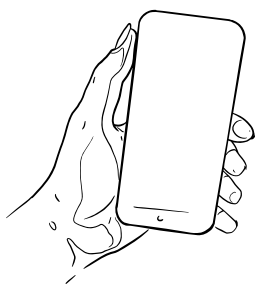

M O B I L E

MOBILE PHONE OR TABLET
WITH BLUETOOTH AND
LATEST VERSION OF
VCHRGD INSTALLER APP

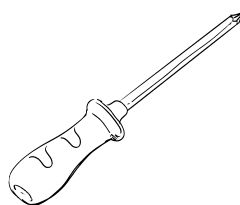

S C R E W D R I V E R

INTERCHANGEABLE BIT
SCREWDRIVER TO ALLOW FOR
PHILLIPS HEAD (MOUNTING)
FLAT HEAD (DATA LINES) AND
TORX+ (CASE) DRILL BITS

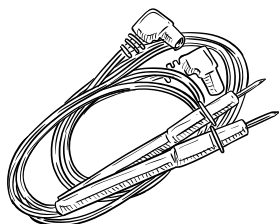

T E S T E R

SUITABLE CHARGEPOINT
TEST EQUIPMENT, IDEALLY
WITH A TYPE 2 CONNECTOR
TO ALLOW SESSION & SAFETY
TESTS UNDER LOAD/NO LOAD

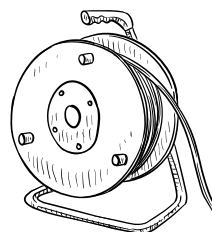

A D D I T I O N A L

EV CABLE (3 CORE + TWISTED
PAIRS (10MM MAX), RCBO TYPE A
(40A), SPD AND MINI ENCLOSURE
IF REQUIRED FOR INSTALLATION

I N S T A L L A T I O N

P R O T E C T I O N

Safety precautions for installation:

The TwentyTwo Pro has integral RCD protection rated at (AC 30 mA DC 6 mA) the 6 mA DC fault current disconnection device was verified to the IEC 62955 standard.

It is necessary to install a 40A 4 pole RCBO/RCD Type A at the origin of the installation, for multi level safety protection (the RCD Type A should be tested and maintained in accordance with BS 7671 for all UK installations).

SINCE 27TH SEPTEMBER 2022 THE NEW 18TH EDITION AMENDMENT 2 OF THE WIRING REGULATIONS CAME INTO EFFECT WITH THESE NEW REGULATIONS, ALL NEW ELECTRICAL CIRCUITS MUST HAVE SURGE PROTECTION DEVICES FITTED SOME INSTALLERS MAY CHOOSE TO ENTER INTO AN OPT OUT AGREEMENT WITH THE CUSTOMER HOWEVER THIS IS THE SOLE RESPONSIBILITY OF THE INSTALLER TO AGREE WITH THE END USER PRIOR TO INSTALLATION

P R E - D R I L L E D M O U N T I N G

THE TOP 3 MOUNTING POINTS ARE PRE-DRILLED, PROVIDING A ROBUST TRIANGULAR MOUNTING PLANE.

THE BOTTOM-MOST MOUNTING POINT CAN ALSO BE DRILLED AND REINFORCED WITH THE SPARE METAL GASKET SUPPLIED IN THE FIXINGS PACK, FOR MOUNTING TO UNEVEN SURFACES.

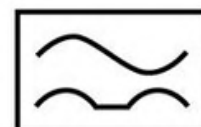

4 P O L E R C B O T Y P E A
40A RECOMMENDED TO MITIGATE
NUISANCE TRIPPING UNDER LOAD
LIVE, NEUTRAL & PE LINES
MARKED IN MOUNTING PLATE
PLASTICS AS L,N,PE

● R E A R A C C E S S

MEMBRANE GLANDED ENTRY POINT,
CABLE DIAMETER LIMITED TO 6MM

● B O T T O M A C C E S S

STUFFING GLAND PROVIDED IN BOX TO
ALLOW FOR 6MM BOTTOM ENTRY IF
REQUIRED

I N S T A L L A T I O N

S A F E T Y N O T I C E

I M P O R T A N T S A F E T Y I N F O R M A T I O N

Installation Safety Precautions

1. Isolate the Power Supply

- Before exposing or working with any live terminals, or removing the charge point from the back box after installation, the incoming supply must be fully isolated.
- Failure to isolate the power could result in severe electric shock or equipment damage.

2. Secure Terminal Connections

- Ensure that all incoming power lines are tightly connected at the terminals. Loose connections may lead to overheating, electrical faults, or fire risks.

3. Correct Earthing

- The charge point must be correctly earthed in accordance with local electrical regulations.
- Improper earthing can lead to electric shock hazards and equipment malfunction.

4. Fasten Fixing Points and Screws Securely

- After installation, confirm that all fixing points and screws are securely tightened.
- Loose hardware may result in instability, potential detachment, or exposure to electrical components.

User Safety Precautions

- Do not tamper with the charge point's internal components. Only qualified personnel should access internal wiring.
- Inspect regularly for signs of wear, damage, or loose connections. If any issues arise, discontinue use and contact a certified installer.

Failure to adhere to these safety guidelines may result in injury, electrical faults, or damage to the unit. Always ensure installation and maintenance are performed by a qualified electrician.

For further guidance, refer to the VCHRGD TwentyTwo Dual Installation Manual or contact our support team.

I N S T A L L A T I O N

M O U N T I N G

Whether wall mounted or pedestal mounted, the TwentyTwo Pro is designed for ease of installation. With 4 mounting points designed to evenly distribute the load of every day use, the Pro is quick and easy to fit into place no matter where you decide to put it.



Each fixing point is designed to facilitate the mounting screws provided with the unit, if using alternative fixings please ensure the diameter is equal to the screws provided.

The fixing points are secured with a rubber gasket internally to ensure that the unit retains its IP rating, please ensure that the fixings are sufficiently tightened and that the integrity of the rubber seal on each fixing point is maintained after tightening.

I N S T A L L A T I O N

W I R I N G T E R M I N A T I O N

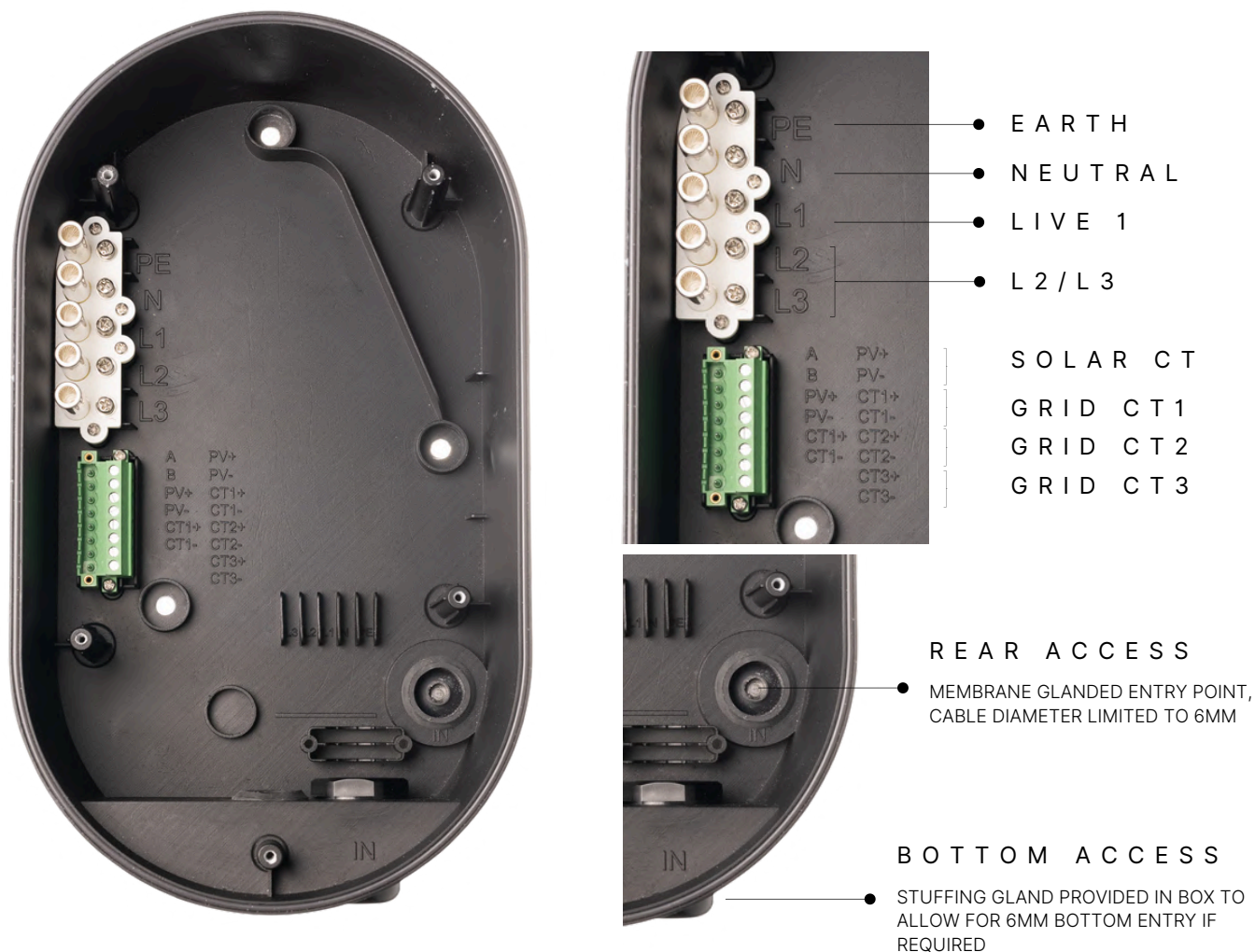

The Pro Series is defined by its ease of installation and flexibility, making wiring simple and offering ample working space and cable entry ways. Once the cable has been run into the charger either via the back or bottom entry points, strip back the cable sheath to expose the relevant cores, route the cable to the appropriate terminals, ensuring a tight connection to the Live, Neutral, PE & data lines. You can then route the cables through the raised cable guides to ensure a neat fit and finish if required.

Once complete, push fit the charging hardware to the back box, securing in place with the 5x Torx+ security screws provided to be fixed at the points market 'Mounting hole'. Replace the front plate to ensure tamper detection isn't activated before moving to test & commissioning.

I N S T A L L A T I O N

C H A R G I N G H A R D W A R E

Utilising high reliability & low thermal dissipation connectors, the Pro Series makes installation, maintenance and returns quick and easy through our push fit installation method.

Once wiring has been completed, simply push the charging hardware into place and secure with the mounting plate screws and Torx+ drill bit provided, then replace the front plate to pair tamper detection sensor.

NOTE: YOU MAY WISH TO TEST THE UNIT PRIOR TO FIXING THE CHARGING HARDWARE TO THE BACK BOX SO THAT ANY FAULTS OR ISSUES CAN BE DEBUGGED EASILY. PROVIDED THE TAMPER SENSOR IS PAIRED WITH THE FRONT PLATE IN PLACE THEN THIS IS POSSIBLE.

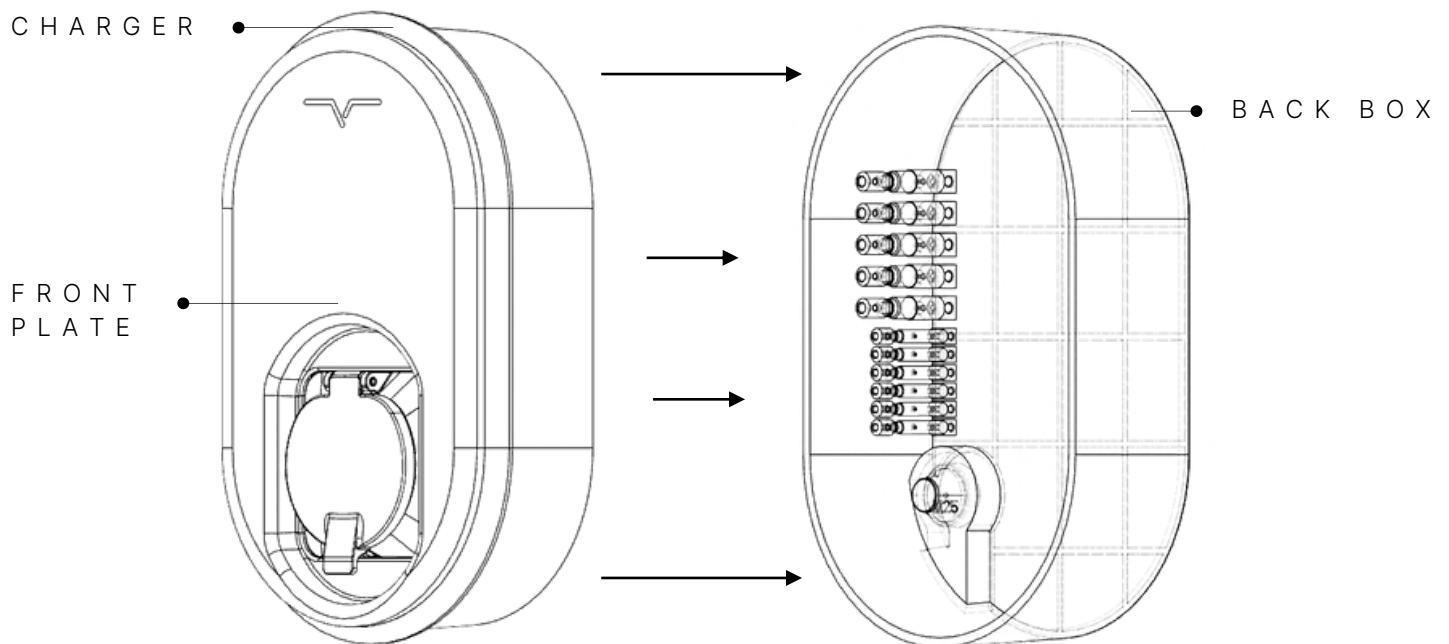

I N S T A L L A T I O N

D E T A I L E D G U I D E

For ease of use, the 3 segments of the TwentyTwo Pro come separated in the box, allowing you to easily extract the segment you require at each stage of the installation.

Firstly, remove the Back Box / Mounting Panel after using the drilling template to mark up and drill the mounting holes.

Once all power line and CT connections have been securely terminated, take the central charging hardware and push fit securely into the back box.

Next, secure the charging hardware to the back box using the Torx+ screws, rubber gaskets and drill bit provided, at the marked mounting holes.

Finally, you can clip the Front Plate/Tamper Panel to the front of the charger. Either by guiding the bottom of the panel into the clip in points and then securely clipping into place at the top of the unit, or guiding from the resting clip at the top and gently depressing the flexible clips at the bottom to guide them into the clip in points until secure.

To remove the front plate, gently push it upwards from the bottom and work down from the top to carefully prise away from the charging hardware until removed.

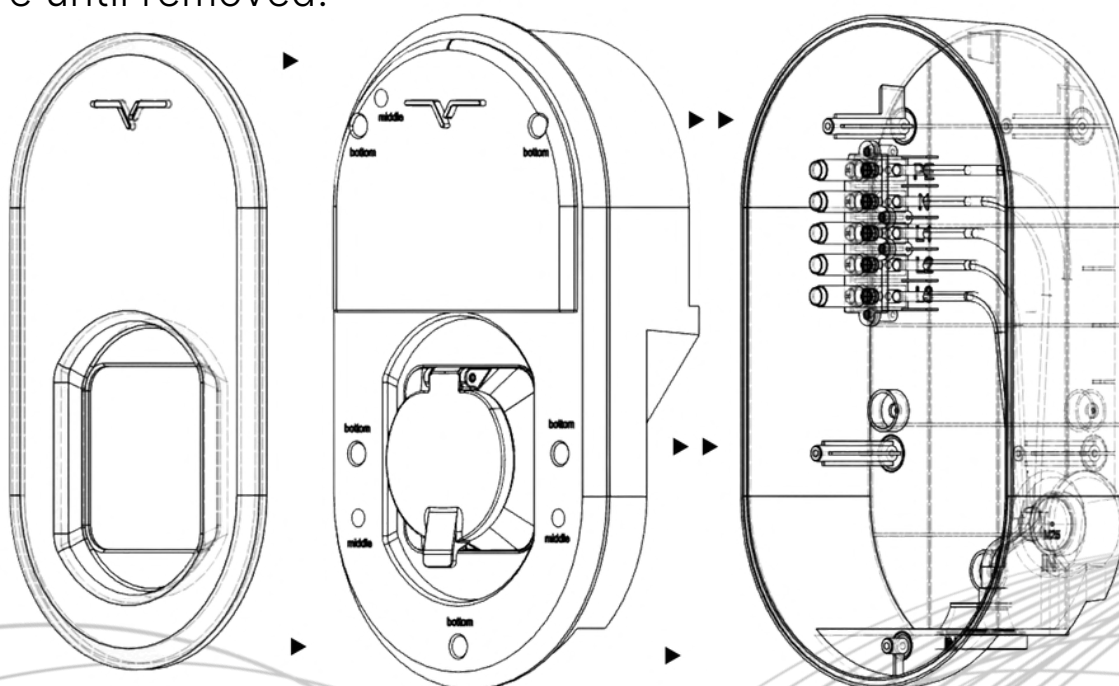

I N S T A L L A T I O N

S O L A R & L O A D M A N A G E M E N T

Combining the tried and tested grid export solar functionality, of our previous product family with another CT connection, the TwentyTwo Pro has enhanced solar functionality, with all the reliability & safety of dynamic load management.

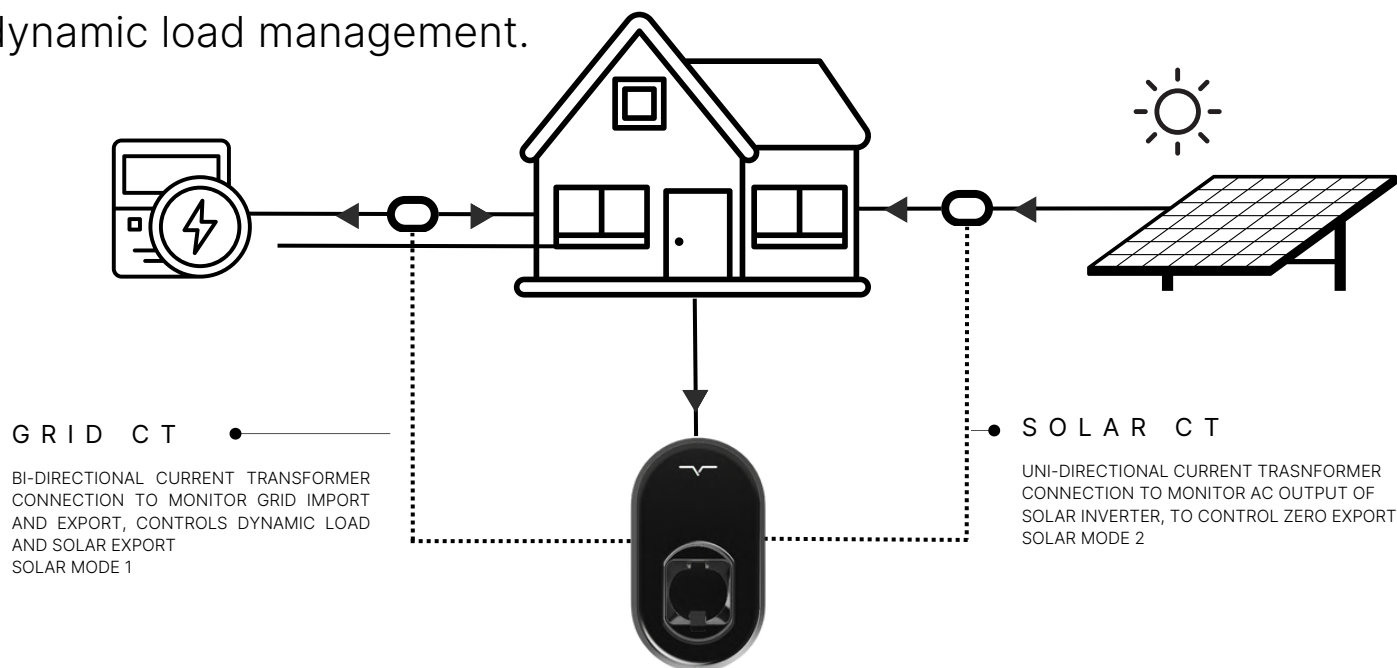

C T C O N N E C T I O N S

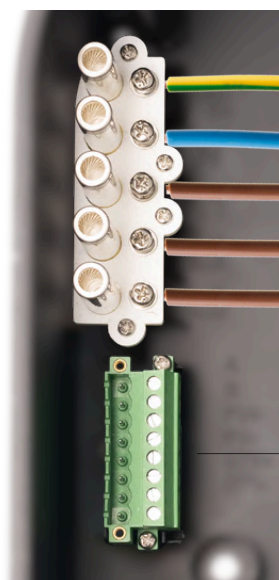

The Pro CT connections are clearly denoted on the back box, with 4x CT inputs for Solar PV and Grid Current monitoring. Loosen the terminals and terminate the CT lines accordingly, ensuring a tight fit. Please note that the connectors pull up to tighten, so fully loosen to ensure fit.



S O L A R C T

UNI-DIRECTIONAL CURRENT TRANSFORMER CONNECTION TO MONITOR AC OUTPUT OF SOLAR INVERTER
CT+ CONNECTION: BLACK CT- CONNECTION: WHITE

G R I D C T 1 / 2 / 3

BI-DIRECTIONAL CURRENT TRANSFORMER CONNECTION TO MONITOR GRID IMPORT AND EXPORT
CT+ CONNECTION: BLACK CT- CONNECTION: WHITE

If extending the CT connections, ensure that only 1 twisted pair is used per CT and that the polarity is matched to the original connections.

If polarity is reversed then this will prevent the solar and dynamic load management features from functioning correctly.

N O T E

PLEASE TAKE CARE TO ENSURE THAT YOU USE THE CORRECT CT MARKINGS. THE BACK BOX MARKINGS ON THE RIGHT HAND SIDE ARE GUIDES FOR THE TERMINALS TO USE FOR 22KW

INSTALLATION

ENERGY MONITORING

DLM & EXPORT MONITOR

The dynamic load management and grid export solar modes are enabled through the Grid CT connections. Ensuring that the CT connections are firmly in place with the polarity matched, connect the CT to the incoming live to the property from the meter. Ensure that the arrow on the CT points in the direction of the incoming flow of electricity. If the polarity is reversed then you can simply flip the CT on the incoming line to correct this.

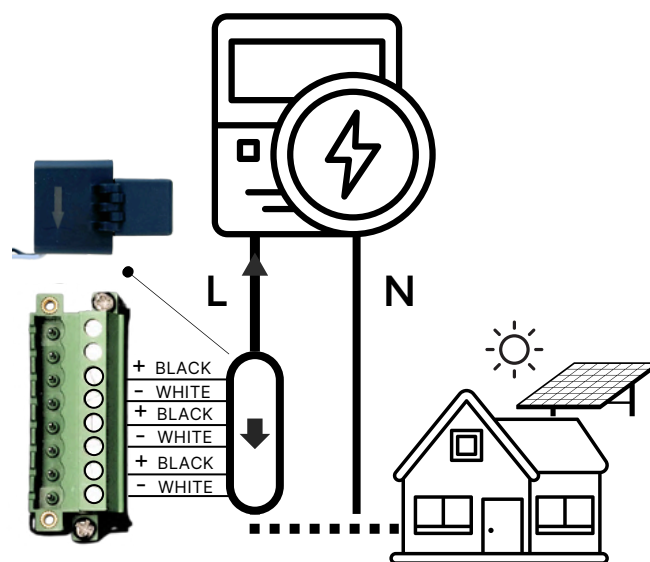

GRID CT CONNECTION

BI-DIRECTIONAL CURRENT TRANSFORMER CONNECTION TO MONITOR GRID IMPORT AND EXPORT

CT+ CONNECTION: BLACK CT- CONNECTION: WHITE

NOTE | SOLAR MODE 1: MONITORS EXPORT TO THE GRID AND MODULATES CHARGING BASED ON THE INPUTS ABOVE

SOLAR ONLY

The dynamic load management and grid export solar modes are enabled through the Grid CT connections. Ensuring that the CT connections are firmly in place, with the polarity matched, connect the CT to the outgoing live to the property from the solar inverter. Ensure that the arrow on the CT points in the direction of the outgoing flow of electricity. If the polarity is reversed then the CT will not read correctly and will need to be corrected.

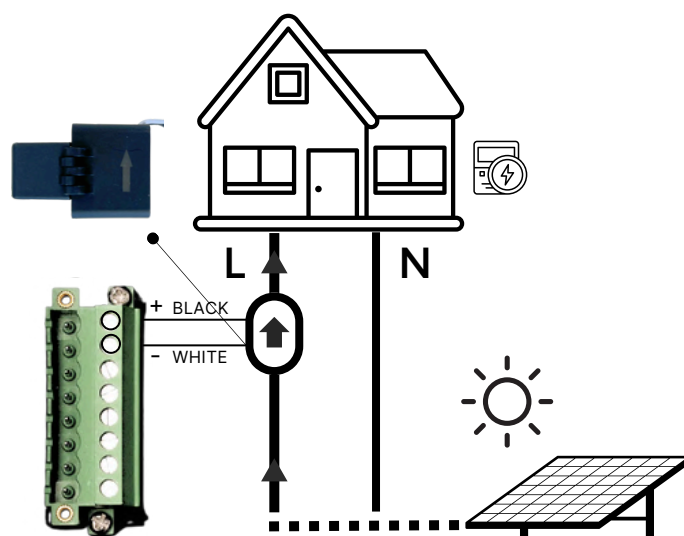

SOLAR CT CONNECTION

UNI-DIRECTIONAL CURRENT TRANSFORMER CONNECTION TO MONITOR AC OUTPUT OF SOLAR INVERTER

CT+ CONNECTION: BLACK CT- CONNECTION: WHITE

NOTE | SOLAR MODE 2: MONITORS EXPORT FROM THE SOLAR INVERTER ONLY, TAKING ALL AVAILABLE SOLAR AC GENERATION AND SENDING IT TO THE VEHICLE

I N S T A L L A T I O N

C O M I S S I O N I N G

The VCHRGD Installer App is a tool designed to enable charge point installers to quickly and easily set up the VCHRGD Pro Series.

Connecting to the charger via Bluetooth, it allows installers to input WiFi credentials, set charge modes, set and change charger passwords define maximum output current & configure load management and solar modes.

D O W N L O A D T H E A P P

Download and install the App from the Google Play or Apple store. Search VCHRGD Installer or VCHRGD to find the app. Once located, tap to download the app to your mobile phone or tablet.

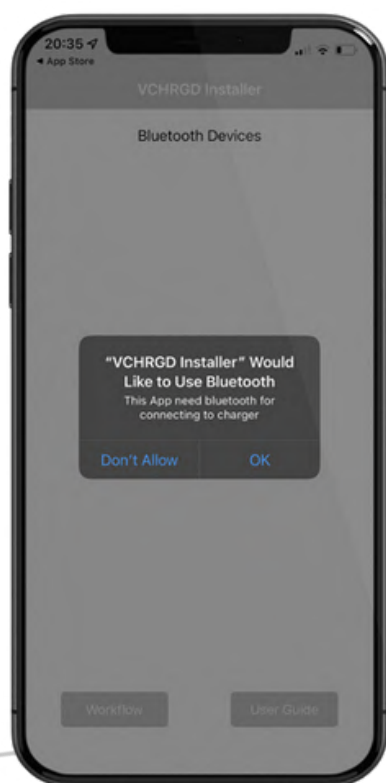
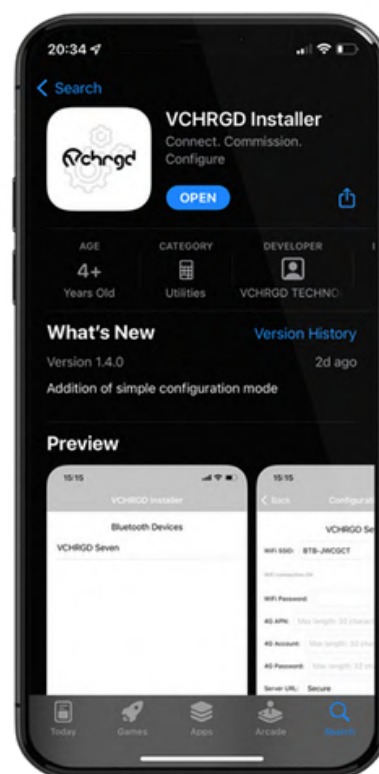

O P E N T H E A P P

Find and tap the VCHRGD Installer Icon on your mobile phone or tablet. When prompted, enable Bluetooth or location permissions (this is required to enable Bluetooth scanning). Ensure that your mobile device has Bluetooth switched on.

I N S T A L L A T I O N

C O M I S S I O N I N G

Open VCHRGD Installer, and the available Bluetooth device list page appears, you should see your charger here. Please note, as this is a Bluetooth connection between the charger and your mobile device, you must be within a 5-10 metre range of the charger whilst attempting to commission.

N O T E

IF THE CONNECTION ATTEMPT TIMES OUT BEFORE CONNECTING, WAIT AND SELECT THE CHARGER AGAIN ONCE VISIBLE, OR SWIPE DOWN ON THE SCREEN TO REFRESH THE LIST OF AVAILABLE BLUETOOTH DEVICES. IF THIS DOESN'T WORK, PLEASE CLOSE DOWN THE APP, TURN BLUETOOTH OFF AND ON AGAIN ON YOUR MOBILE AND REOPEN THE APP.

E N T E R P A S S W O R D

1. Select your charger from the list of devices
2. Enter the password from the Keep Me Guide
3. Tap OK to connect

If you have lost the installer password, please call VCHRGD technical support and quote the Magic No. for a temporary password.

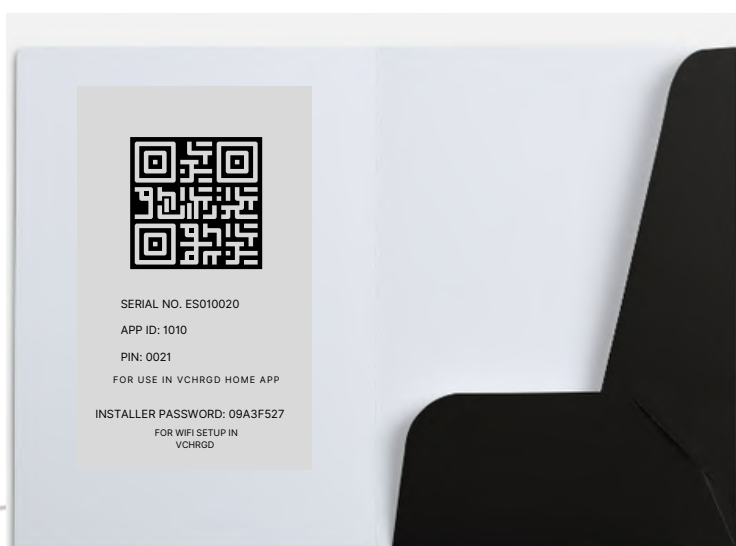
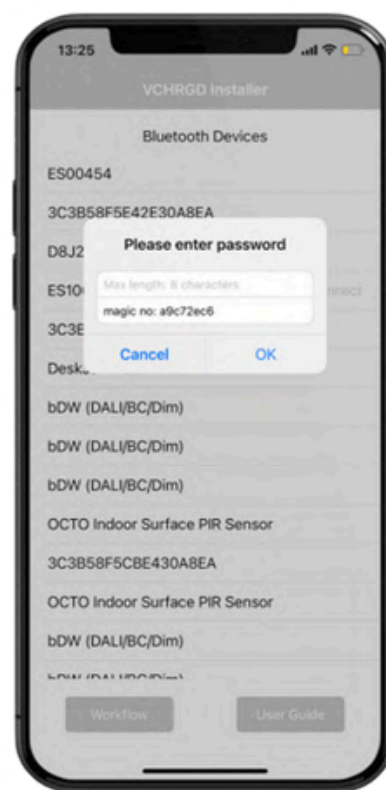

• K E E P M E G U I D E

INSTALLER PASSWORD
SERIAL NUMBER
INSTALL APP QR CODE

I N S T A L L A T I O N

C O M M I S S I O N I N G

S E L E C T C O N F I G M O D E

The installer app will now give you the option of Simple or Full Configuration.

Simple configuration allows you to connect the charger to WiFi and configure the charge mode only.

Full configuration will allow you access to all configuration settings, including load management & back-end settings.

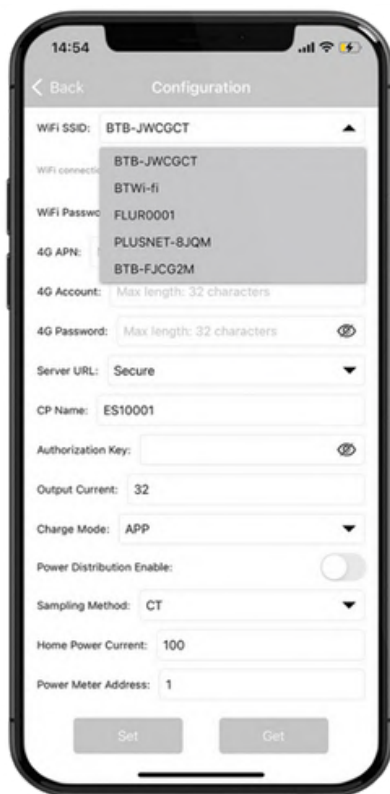
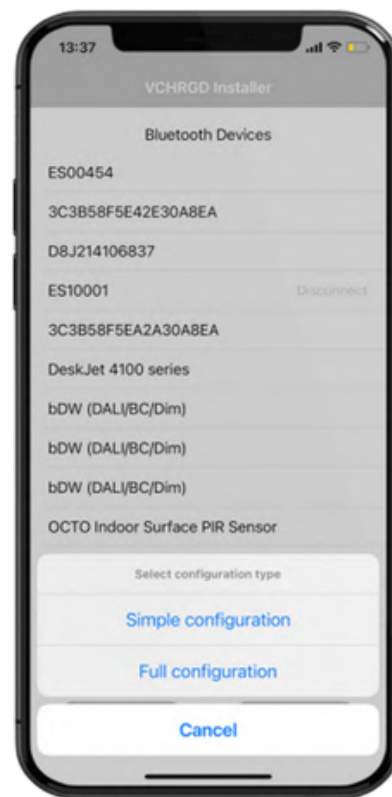

W I F I C O N N E C T I V I T Y

Select customer WiFi from the area scan list (this is a list of 2.4GHz networks that are visible to the charger itself).

Once selected, enter the WiFi password into the field below.

When the charger is in App mode and not yet connected to a valid back-end via WiFi or 4G, the LED status will be yellow, once connected it will turn solid blue.

N O T E

PLEASE NOTE PASSWORD IS CASE SENSITIVE AND IT IS BEST PRACTICE TO DOUBLE CHECK ONCE ENTERED.

I N S T A L L A T I O N

C O M M I S S I O N I N G

4 G C O N N E C T I V I T Y

If your TwentyTwo Pro is 4G enabled as an optional extra, this will be marked on the box and 4G credentials will be provided in the Keep Me Guide.

Enter the 4G APN & Password in the corresponding fields underneath the WiFi fields. WiFi & 4G can be used in tandem, where the 4G will serve as a back-up network in the absence of WiFi.

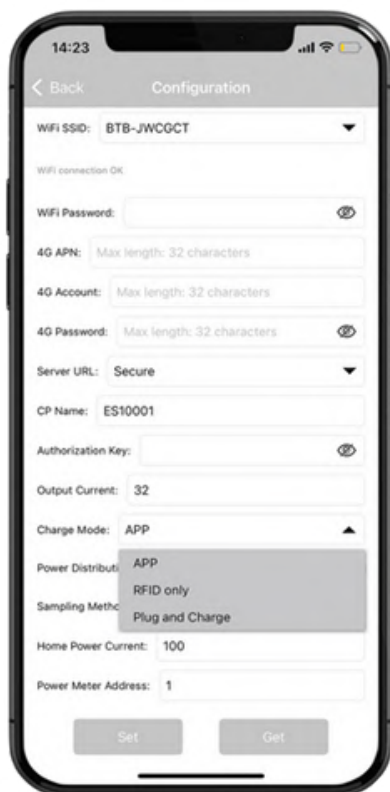
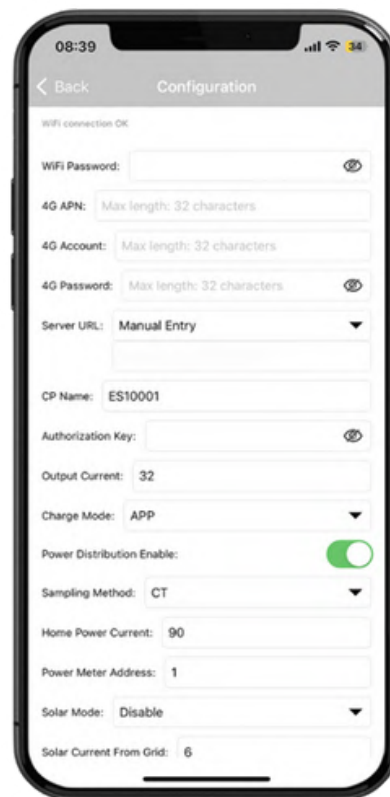

O P E N T H E A P P

If the charger is on a limited circuit and cannot be monitored via DLM ie. a submain, you can configure the output current for the charger, 32A is the default.

Select the charge mode from the drop-down list

App:	App Controlled
RFID Only:	Secure with RFID
Plug & Charge:	Open Charging

N O T E

IF THE CHARGEPOINT IS CONNECTED VIA WIRELESS CONNECTIVITY TO A VALID NETWORK AND THE UNIT IS LEFT IN PLUG & CHARGE OR RFID ONLY MODE, IT WILL PREVENT THE USER FROM USING THE APP CORRECTLY. PLEASE ENSURE THAT THE UNIT IS LEFT IN APP MODE IF YOU HAVE COMMISSIONED IT TO A NETWORK TO PREVENT ANY CUSTOMER ISSUES.

I N S T A L L A T I O N

C O M M I S S I O N I N G

L O A D M A N A G E M E N T

Set the 'Power Distribution Enable' to ON (switch green) and set the home power current according to the maximum rating of the main fuse on the connected circuit. Leave 'Sampling Method' as CT and the 'Power Meter Address' at 1.

Use these settings if a CT clamp is being used and dynamic load management is required to limit the output of the unit.

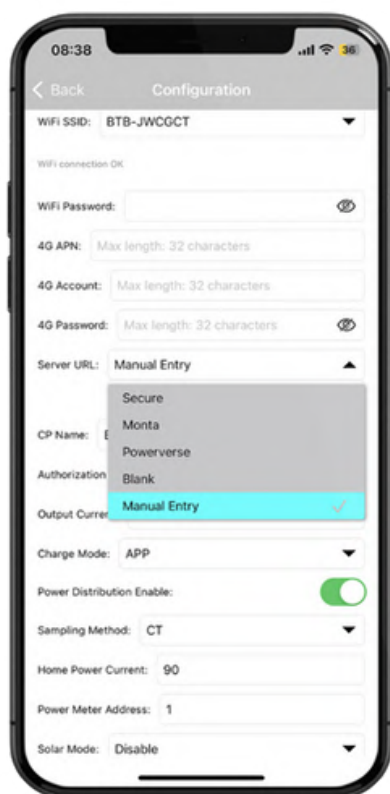
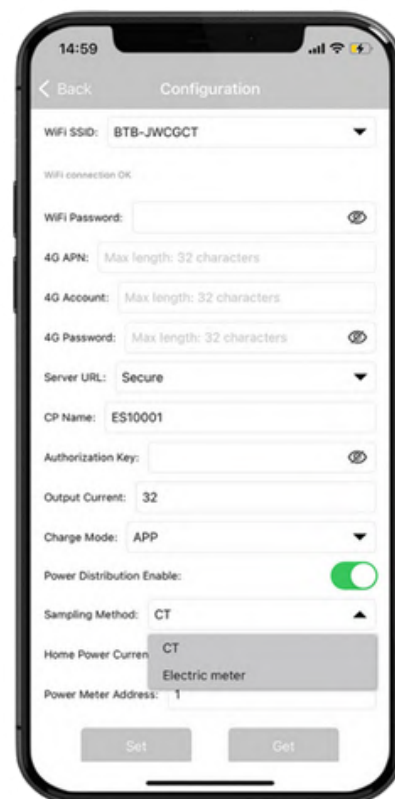

S E R V E R U R L S E T T I N G

The VCHRGD TwentyTwo Pro comes pre-configured to connect to our own OCPP back-end server, with the Server URL field set to Secure. If you wish to use the VCHRGD Home app then leave this field set accordingly and move on.

You can also select Powerverse or Monta as preconfigured back-ends if the unit is being commissioned to these providers. Custom URLs can be entered using 'Manual Entry'.

N O T E

IF COMMISSIONING THE CHARGER TO A THIRD PARTY BACK-END AND THE ORGANISATION, YOU HAVE SEVERAL OPTIONS PRE-POPULATED. IF THE OCPP SERVER YOU WISH TO COMMISSION TO ISN'T PRESET WITHIN THE DROP-DOWN LIST, SCROLL DOWN TO NAVIGATE TO MANUAL ENTRY. FROM HERE YOU CAN ENTER THE CORRECT OCPP SERVER URL, LEAVING NO SPACES AFTER THE ENTRY.

I N S T A L L A T I O N

C O M M I S S I O N I N G

S O L A R S E T T I N G S

There is no need to configure the solar settings via the installer app unless the chargepoint is not connected to any communications network and set to plug & charge or RFID only modes.

Solar Mode 1: Grid Export Monitoring

Solar Mode 2: Solar Inverter Export

Solar current from grid should only be set above 0A if the solar array cannot export more than 6A/1.3kW

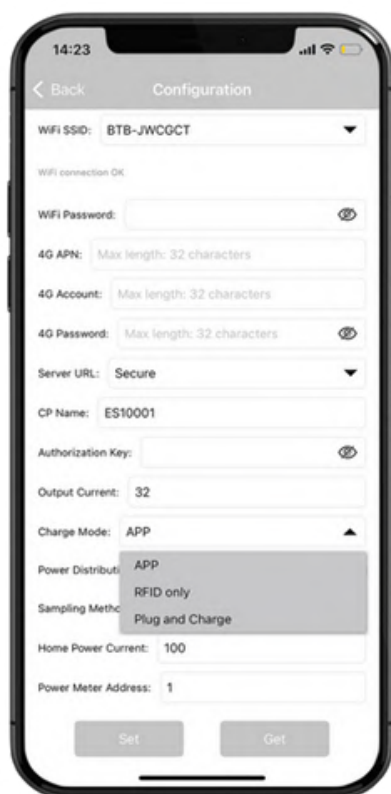
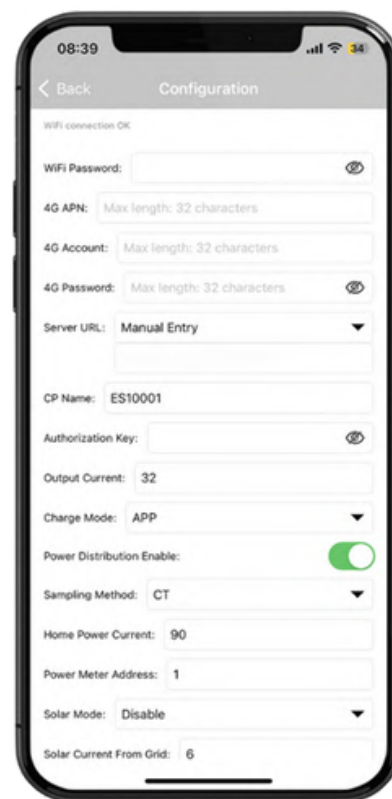

C O M P L E T E C O M I S S I O N

After modifying the page parameter information, click the 'Set' button to send it to the charging point.

If no credentials have been changed since the previous connection then the 'Set' button will be greyed out.

You will then see a 'Set Successfully' message and the installer app will disconnect from the charge point.

N O T E

IF THE INSTALLER APP DOES NOT DISCONNECT AUTOMATICALLY OR NO CREDENTIALS HAVE BEEN CHANGED, TAP THE < BACK BUTTON IN THE TOP LEFT HAND CORNER OF THE APP PAGE AND THEN 'DISCONNECT' TO TERMINATE THE BLUETOOTH CONNECTION WITH THE CHARGER.

S U P P O R T

FAULT CODES

LED STATUS	DESCRIPTION	RESOLUTION
SOLID YELLOW	IN APP MODE BUT NOT CONNECTED TO APP	CHECK SERVER URL OR WIFI/4G DETAILS
SOLID BLUE	CHARGER ON STANDBY	NORMAL BEHAVIOUR
FLASHING GREEN	WAITING TO CHARGE	NORMAL BEHAVIOUR
SOLID GREEN	SESSION STARTED	NORMAL BEHAVIOUR
RED 1 FLASH	RCD/EARTH LEAKAGE	CHECK RCD/SPD & LOAD CONNECTIONS
RED 2 FLASHES	OVERCURRENT FAULT	CHECK RCD/SPD & LOAD CONNECTIONS
RED 3 FLASHES	PE DISCONNECTED	CHECK RCD/SPD & LOAD CONNECTIONS
RED 4 FLASHES	UV/OV FAULT	CONTACT VCHRGD
RED 5 FLASHES	RELAY WELDED	REPLACE POWER BOARD
RED 6 FLASHES	CP FAULT	DISCONNECT PLUG AND CHECK CONNECTIONS
RED 7 FLASHES	ELECTRONIC LOCK FAULT	CHECK SOCKET CONNECTION
RED 8 FLASHES	OVERTEMPERATURE	DISCONNECT CABLE AND WAIT TO CLEAR
RED 9 FLASHES	DIODE LOSS FAILURE	CHECK INTERNAL CONNECTIONS
RED 10 FLASHES	TAMPER DETECTION	REPLACE VANITY PLATE
RED 11 FLASHES	DLB FAULT	DISABLE DLB IN INSTALLER APP
NO LIGHT/WHITE	NO POWER TO UNIT	TEST RCBO AND CHECK CONNECTIONS IN RCD/SPD ENCLOSURE

NOTE

ALL FAULT CODES CAN BE QUICKLY IDENTIFIED AND IN MANY CASES REMOTELY SUPPORTED BY OUR TECHNICAL TEAM. PLEASE CONTACT US VIA THE IN APP LIVECHAT OR ON 01494 370524 IF YOUR CHARGER IS SHOWING A FAULT.

A F T E R S A L E S

W A R R A N T Y

Thank you for choosing the VCHRGD TwentyTwo Pro as your charging solution. In order to ensure that your charger performs to the very best of its ability, correct installation, configuration, use and maintenance are essential.

Please ensure that installation & configuration are in strict accordance with the requirements set out in the "VCHRGD TwentyTwo Pro Installation Guide" and that installation is suitably documented.

Post-installation please ensure that the charger is not operated outside of the conditions specified in the installation manual, product datasheet or technical documentation provided by VCHRGD TECHNOLOGIES LTD or authorised partners.

S E R V I C E H O U R S

W O R K I N G H O U R S

MONDAY TO FRIDAY, 08:30- 18:00PM (EXCEPT NATIONAL AND PUBLIC HOLIDAYS)
SUPPORT AVAILABLE ON:

- IN APP LIVECHAT
- SUPPORT LINE: 01494 370524
- WEBSITE LIVECHAT

O U T O F H O U R S T E C H N I C A L S U P P O R T

MONDAY TO SUNDAY, 24 HOURS A DAY INCLUDING BANK HOLIDAYS

- CALL OUR TECHNICAL SUPPORT LINE AND LEAVE A VOICEMAIL
- SUBMIT A SUPPORT TICKET THROUGH LIVECHAT

C O N T A C T I N F O R M A T I O N

W H E R E T O F I N D U S

- TELEPHONE: +44 1494 370523
 - EMAIL: INFO@VCHRGD.COM
 - WEBSITE: WWW.VCHRGD.COM
 - ADDRESS: VCHRGD TECHNOLOGIES LTD, UNIT1A EGHAMS COURT,
BOURNE END,
HIGH WYCOMBE,
SL85YS
- 

A F T E R S A L E S

W A R R A N T Y

L I M I T A T I O N O F D A M A G E S

In no event shall VCHRGD TECHNOLOGIES LTD be liable for consequential damages for breach of this warranty, or for faults occurring outside of the defined warranty period.

W A R R A N T Y S E R V I C E

VCHRGD TECHNOLOGIES LTD warrants that the VCHRGD TwentyTwo Pro is to be free of all defects in material, charging functionality and compliance where installation has been carried out in accordance with the guidelines laid out in the VCHRGD TWENTYTWO PRO INSTALLATION GUIDE.

The warranty period extends for 3 years from the date of first installation. The warranty extends to the original buyer and each subsequent buyer within the warranty period where proof of sale, and installation compliance can be proven.

Within the period of this warranty [3 years], VCHRGD TECHNOLOGIES LTD will repair or replace the VCHRGD TWENTYTWO Pro, free of charge, any part providing defective. Warranty liability is exclusively limited to internal componentry, physical housing of the charger or tethered cable if defective on delivery and charging functionality defined within the product datasheet and promotional material generated and distributed by VCHRGD TECHNOLOGIES LTD and authorised partners.

Where possible, VCHRGD TECHNOLOGIES LTD reserve the right to repair the charger on-site, where this is not possible a like for like replacement unit will be provided free of charge. All warranty repairs, replacements and servicing must be performed by an authorised VCHRGD TECHNOLOGIES approved installer, or fully qualified electrician in accordance with British Wiring Standards BS7671. All expenses relating to the replacement or repair of the TWENTYTWO PRO under this warranty shall be assumed by VCHRGD TECHNOLOGIES LTD.

A F T E R S A L E S

W A R R A N T Y

W A R R A N T Y E X C L U S I O N S

This warranty does not apply to any costs, repairs or services required as a result of the following:

1. Service calls to correct the installation of the VCHRGD TwentyTwo, derived from faulty switchgear, incorrect cabling, insufficient protection or non-compliance with the VCHRGD TwentyTwo INSTALLATION GUIDE
2. Repairs necessitated by improper use, vandalism or any use other than normal usage as specified within VCHRGD Technical documentation
3. Corrective work necessitated by repairs made by anyone other than a VCHRGD TECHNOLOGIES approved installer, or fully qualified electrician in accordance with British Wiring Standards BS7671

P A I D S E R V I C E

If the product cannot be used normally due to improper use during the warranty period, the after-sales service personnel will charge a certain fee according to the actual situation of the damaged product and implement paid services. The details are as follows:

1. Damage caused by users due to improper use, maintenance, and storage
 2. Damage caused by unauthorised disassembly by the user
 3. Charger without warranty certificate or valid invoice
 4. The product name and model on the warranty certificate or valid invoice are inconsistent or altered with the product name and model under warranty
 5. Damaged due to force majeure or natural disasters
 6. Service calls to correct the installation derived from faulty switchgear, incorrect cabling, insufficient protection or non-compliance with the VCHRGD TWENTYTWO PRO INSTALLATION GUIDE.
- 

A F T E R S A L E S

W A R R A N T Y

H O W T O O B T A I N W A R R A N T Y S E R V I C E

The buyer must notify VCHRGD TECHNOLOGIES LTD of any defect, malfunction, on non-conformity promptly upon discovery, by calling 01494 370526.

VCHRGD TECHNOLOGIES LTD will arrange for an authorised installer to visit the buyers location for the purpose of repairing or replacing the VCHRGD TWENTYTWO PRO in a timely fashion and in accordance with the buyers availability where possible.

So that our service staff can quickly locate the cause of the problem, and work to find a resolution it is best to provide a photo or video with your warranty claim.

R E C Y C L I N G

The VCHRGD TwentyTwo Pro is shipped in a rigid cardboard box with a cardboard sleeve fitted around the outside, these can be recycled or reused. Please ensure you separate all plastic packaging used in accordance with your local recycling guidelines.

We'd love for you to keep the box, that way if you ever move home and want to take it with you, everything can be easily and securely packed up.

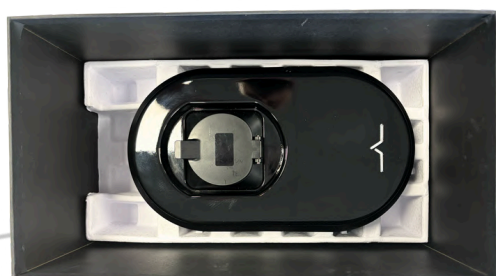

A F T E R S A L E S R E C Y C L I N G

R E C Y C L I N G E L E C T R I C A L E Q U I P M E N T

Why Recycle?

Unwanted electrical equipment is the UK's fastest growing type of waste. Many electrical items can be repaired or recycled, saving natural resources and the environment. If you do not recycle, electrical equipment will end up in landfill where hazardous substances will leak out and cause soil and water contamination – harming wildlife and human health.

We can help...

We are pleased to offer our customers the chance to recycle old VCHRGD products when purchasing a new item from us or servicing a warranty replacement. Please speak to a member of staff for details on how to dispose of your Waste Electrical or Electronic Equipment (WEEE).

Crossed out wheeled-bin symbol

To remind you that old electrical equipment can be recycled, it is now marked with a crossed-out wheeled bin symbol. Please do not throw any electrical equipment (including those marked with the crossed out wheeled bin symbol) in your bin.



The Waste Electrical and Electronic Equipment Regulations 2013